



## Shark WV200 WANDVAC Cordless Handheld Vacuum User Manual

[Home](#) » [Shark](#) » Shark WV200 WANDVAC Cordless Handheld Vacuum User Manual 

## Contents

- 1 Shark WV200 WANDVAC Cordless Handheld Vacuum User Manual
- 2 IMPORTANT SAFETY INSTRUCTIONS
  - 2.1 GENERAL USE
  - 2.2 DUST CUP/FILTERS/ACCESSORIES
  - 2.3 GENERAL CLEANING
  - 2.4 LITHIUM-ION BATTERY
- 3 WHAT'S INSIDE
- 4 WANDVAC CHARGING STAND ASSEMBLY
- 5 CHARGING THE BATTERY
- 6 USING YOUR SHARK® WANDVAC™
- 7 MAINTENANCE
  - 7.1 EMPTYING THE DUST CUP
  - 7.2 CLEANING THE DUST CUP
- 8 CLEANING THE FILTER
- 9 TROUBLESHOOTING AND ERROR CODES
- 10 REGISTER YOUR PURCHASE
- 11 TECHNICAL SPECIFICATIONS
- 12 TWO-YEAR LIMITED WARRANTY
- 13 RECORD THIS INFORMATION
- 14 DOWNLOAD
- 15 Related Posts

## Shark WV200 WANDVAC Cordless Handheld Vacuum User Manual



WV200 WANDVAC  
OWNER'S GUIDE

## IMPORTANT SAFETY INSTRUCTIONS

- FOR HOUSEHOLD USE ONLY
- READ CAREFULLY BEFORE USE
- SAVE THESE INSTRUCTIONS

## **WARNING**

To reduce the risk of injury, fire, electric shock, and property damage resulting from improper use of the appliance, carefully observe the following instructions. This unit contains electrical connections and moving parts that potentially present risk to the user.

## **POWER SUPPLY, CHARGING DOCK, AND VACUUM CONTAIN ELECTRICAL CONNECTIONS:**

1. There are NO serviceable parts.
2. DO NOT use to vacuum any liquids.
3. DO NOT immerse in water or other liquids.
4. If vacuum is damaged, discontinue use.
5. To avoid fire, explosion, or injury, inspect vacuum and charging dock for any damage before use. DO NOT use damaged vacuum or charging dock.
6. DO NOT use outdoors or on wet surfaces. Use only on dry surfaces.
7. If vacuum cleaner is not working as it should, or has been dropped, damaged, left outdoors, or immersed in water, return it to SharkNinja Operating LLC for examination, repair, or adjustment.
8. DO NOT handle charger or vacuum cleaner with wet hands.
9. DO NOT leave vacuum cleaner unattended while powered on.
10. Keep vacuum away from heated surfaces.
11. Always turn off vacuum before connecting charging dock.
12. Use only Shark® chargers and batteries. Other types of batteries may burst, causing injury and damage.
13. Use charging dock on flat and stable surfaces only.
14. DO NOT incinerate appliance, even if it is severely damaged, as lithium-ion battery may explode in a fire.

## **GENERAL USE**

15. DO NOT carry the charger by the cord or yank to disconnect from an outlet; instead grasp the plug and pull to disconnect.
16. Keep charger cord away from heated surfaces.
17. Use only as described in this manual.
18. Keep your work area well lit.
19. To avoid unintentional starting, always turn off the vacuum cleaner before picking it up or carrying it, and before attaching or detaching the charger, dust cup, filter, or any accessories.
20. DO NOT put any objects into openings.
21. DO NOT use if any opening is blocked; keep free of dust, lint, hair, or anything that may reduce airflow.
22. This vacuum is not a toy, and must not be played with. Children over 8 years old and persons with reduced physical, sensory, or mental capabilities may only use the vacuum with supervision or prior safety instruction and an understanding of the hazards involved. Children may not clean or maintain the vacuum without supervision.
23. DO NOT use without dust cup and filter in place.
24. DO NOT use if airflow is restricted; if the air paths become blocked, turn off the vacuum cleaner. Clear all obstructions and power on again.
25. Keep nozzle away from hair, face, fingers, uncovered feet, or loose clothing.
26. Only use manufacturer's recommended attachments.
27. DO NOT charge at temperatures below 50°F (10°C) or above 104°F (40°C). Charging improperly or at temperatures outside of the specified range may damage the battery and increase the risk of fire.
28. Store the appliance indoors. DO NOT use or store it below 37.4°F (3°C). Ensure the appliance is at room temperature before operating.

## **DUST CUP/FILTERS/ACCESSORIES**

Before turning on the vacuum:

29. Make sure filter is thoroughly dry after routine cleaning.
30. Make sure dust cup and filter are in place after routine maintenance.
31. Make sure accessories are free of blockages and keep openings away from face and body.
32. Use only Shark® brand filters and accessories. Using other brands will void warranty.

## GENERAL CLEANING

33. DO NOT vacuum up hard or sharp objects such as glass, nails, screws, or coins that could damage the vacuum cleaner.
34. DO NOT vacuum up drywall dust, fireplace ash, or embers.
35. DO NOT use as an attachment to power tools for dust collection.
36. DO NOT vacuum up smoking or burning objects such as hot coals, cigarette butts, or matches.
37. DO NOT vacuum up flammable or combustible materials (e.g., lighter fluid, gasoline, or kerosene) or use vacuum in areas where they may be present.
38. DO NOT vacuum up toxic solutions (e.g., chlorine bleach, ammonia, or drain cleaner).
39. DO NOT use in an enclosed space where vapors are present from paint, paint thinner, moth-proofing substances, flammable dust, or other explosive or toxic materials.
40. DO NOT immerse vacuum cleaner in water or other liquids.
41. Use extra care when cleaning on stairs.

## LITHIUM-ION BATTERY

42. The battery is the power source for the appliance. DO NOT carry the appliance with your finger on the power button. DO NOT charge appliance with the power on.
43. Use only the included charging dock to charge. Use of incorrect charger may create a risk of fire.
44. Use appliance only with included lithium-ion battery. Use of any other battery may create a risk of injury and fire.
45. Under abusive conditions, liquid may be ejected from the battery. Avoid contact with liquid, as it may cause irritation or burns. If contact occurs, flush with water. If liquid contacts eyes, seek medical help.
46. Store the appliance indoors. To maintain battery life, DO NOT use or store battery at temperatures below 37.4°F (3°C) or above 104°F (40°C).
47. DO NOT expose appliance to fire or temperature above 266°F (130°C) as it may cause explosion.
48. There are NO serviceable parts. To ensure safety, DO NOT modify or attempt to repair the appliance.

## WHAT'S INSIDE

- A. Shark® WANDVAC™
- B. Crevice Tool
- C. Multi-Surface Pet Tool
- D. WANDVAC Charging Stand
- E. WANDVAC Charging Base

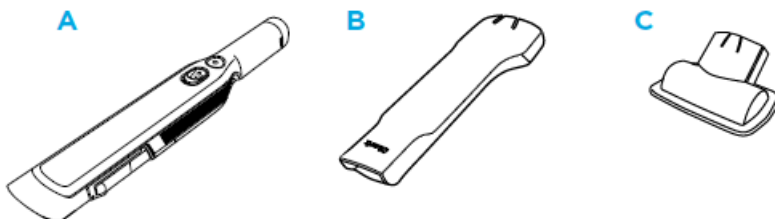

## WANDVAC CHARGING STAND ASSEMBLY

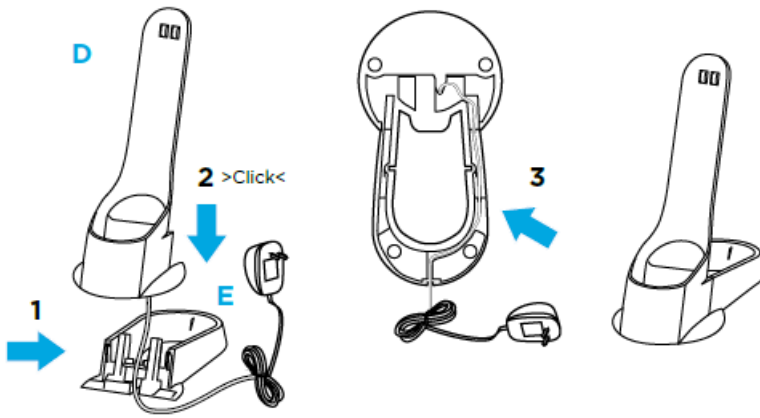

1. Align the holes in the bottom of the WANDVAC Charging Stand with the posts on the front of the Charging Base. Run the Charger Cord between the posts.
2. With the cord in place, slide the stand down until it clicks securely into place on the base.
3. Route the cord through the groove in the bottom of the base and out the indent in the back.

### CHARGING THE BATTERY

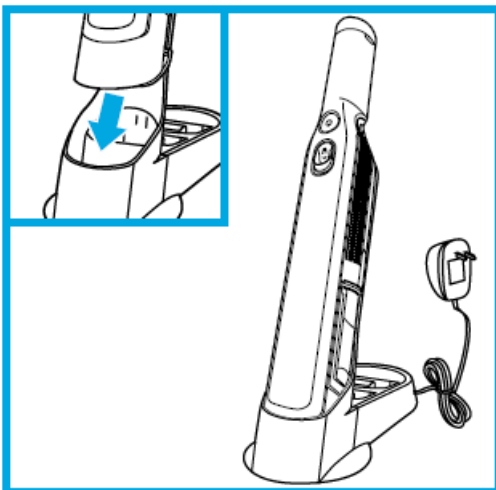

Prior to first use, the lithium-ion battery must be charged completely, even if it comes with a partial charge. Place the Shark® WANDVAC™ onto the WANDVAC Charging Dock with the nozzle in the cradle. Plug the charging dock into a wall outlet.

#### In Use



Solid blue

#### Low Battery



Blinking

#### Charging



Fades in and out

#### Charged



Dim

**NOTE:** During first use, run the battery all the way down to properly condition it, then charge fully. It takes approximately 2.5 hours to charge battery completely.

## USING YOUR SHARK® WANDVAC™

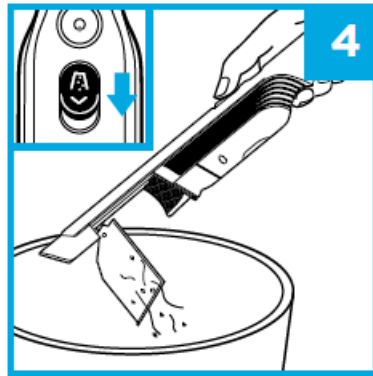
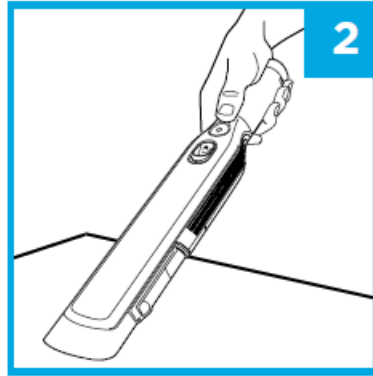
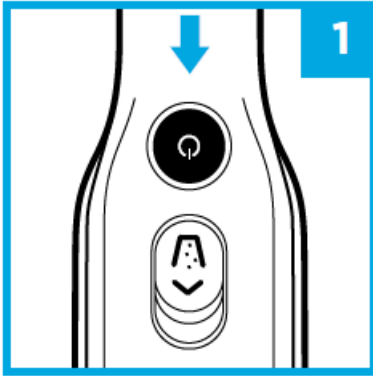

1. Press Power button.
2. Run the nozzle over the surface to be cleaned.
3. To empty dust cup, hold your WANDVAC over the trash.
4. Slide dust cup button forward to release debris.

**NOTE:** For maintenance, see reverse side.

## MAINTENANCE

### EMPTYING THE DUST CUP

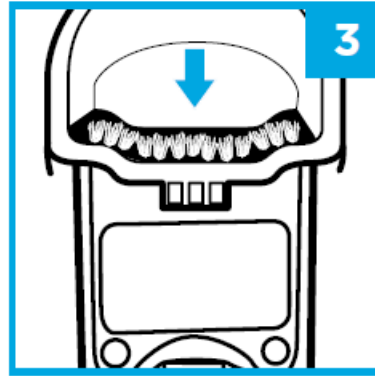
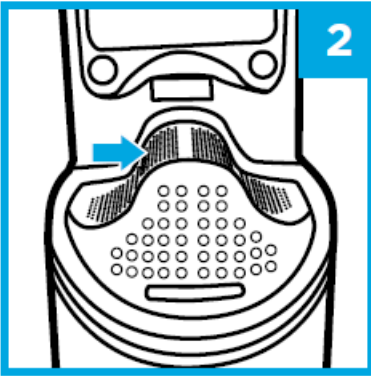
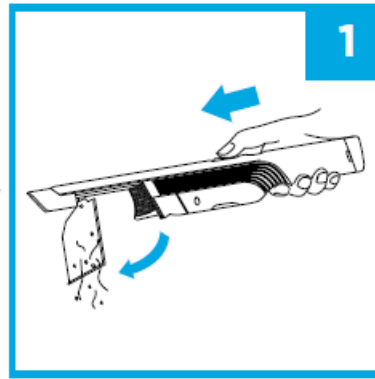
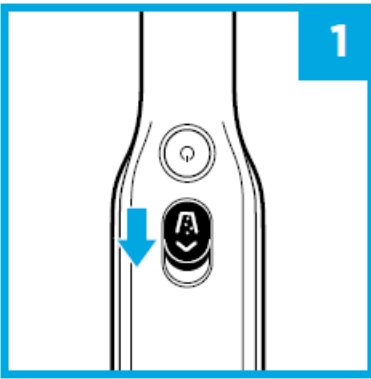

1. With the power off, slide the Open Dust Cup button forward, and the dust cup will swing open.
2. Tap dust cup filter screen lightly to knock off dust and debris.
3. Wipe dust cup bristle lightly with dry cloth to remove dust and dirt.

#### CLEANING THE DUST CUP

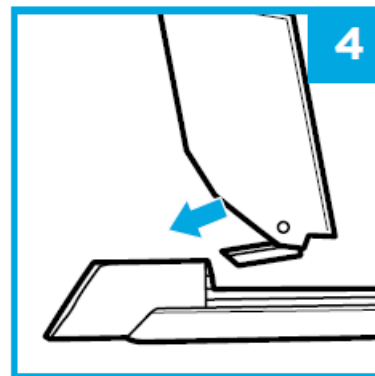
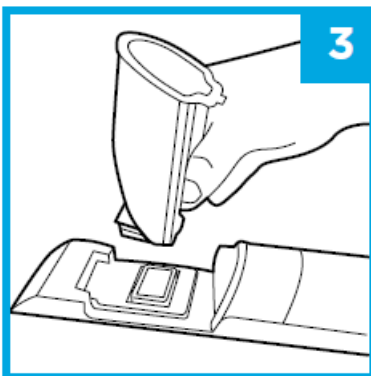
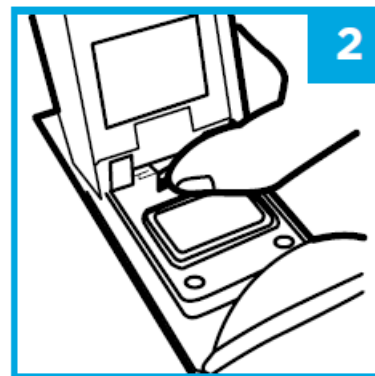
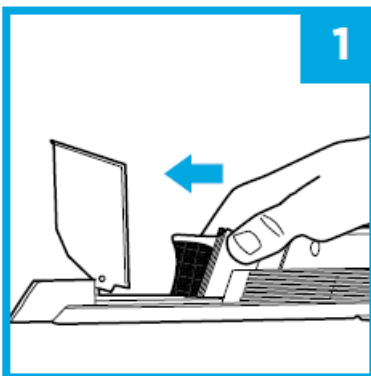

1. With the dust cup open and the power off, pinch both sides of the filter housing and slide it forward to remove.
2. With the dust cup open, push the release button.
3. While holding in the button, lift off the dust cup, then hand-wash it with soap and water only. Let parts air-dry

fully before reinstalling.

4. To reinstall, slide the tab on the dust cup into the slot on the bottom of the nozzle until it clicks into place.

Do not wash any parts of this vacuum or its accessories in a dishwasher.

## CLEANING THE FILTER

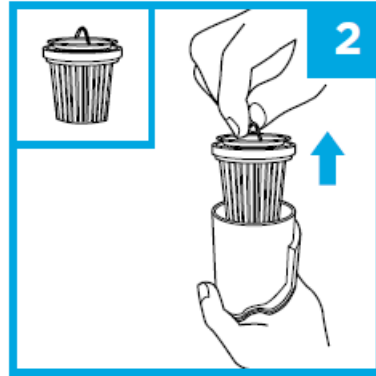
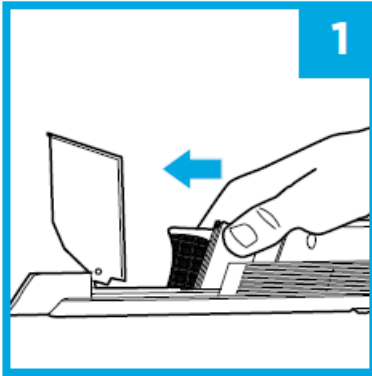

1. With the dust cup open and the power off, pinch both sides of the filter housing and slide it forward to remove.
2. Over a trash can lift the fabric filter by the metal ring to remove it from the housing.

To clean the fabric filter, tap to remove dust and large particles. For deeper cleaning, hand-wash the filter with water only and let it air-dry for 24 hours before reinstalling.

To clean the filter housing, make sure filter is removed, then hand-wash with water only.

## TROUBLESHOOTING AND ERROR CODES

LIGHT INDICATOR	WHAT IT MEANS
Light blinking blue	Low battery.
Light blinks blue twice, then pauses	Blockage. Turn off power and remove blockage, then turn power back on.
Solid blue light	Power is on.
Blue light fades in and out steadily	Unit is charging.
Dim blue light	Unit is fully charged.
No light	Power is off, or unit needs to recharge.

Find FAQs and additional accessories available for purchase at [sharkclean.com](https://www.sharkclean.com)



### **The Shark® WANDVAC™ will not operate.**

- The battery needs to be recharged.
- Try using a different electrical outlet to charge.
- The battery is damaged and needs to be replaced.

### **The Shark WANDVAC will not pick up debris or suction is weak.**

- The dust cup is full. Empty the dust cup.
- The fabric filter needs cleaning or replacement. Clean or replace the fabric filter.
- The battery needs to be recharged.
- The filter screen is clogged and needs cleaning. Open dust cup and clean filter screen.

### **Dust is escaping from the Shark WANDVAC.**

- The fabric filter is not installed correctly. Remove filter, then reinstall.
- The dust cup fabric filter has a hole or a puncture and needs to be replaced.
- The dust cup is not installed correctly. Remove dust cup, then reinstall.

### **I dropped my unit and the dust cup fell off.**

- To reinstall, slide the tab on the dust cup into the slot on the bottom of the nozzle until it clicks into place.

## **REGISTER YOUR PURCHASE**

[registeryourshark.com](https://registeryourshark.com)

Scan QR code using mobile device



## **TECHNICAL SPECIFICATIONS**

Battery Voltage: 10.8V

Motor Watts: 115W

Amps: 10.6A

Shark WANDVAC Cord-Free Handheld Vacuum charger part number: 1076FI200

## **TWO-YEAR LIMITED WARRANTY**

The Two (2) Year Limited Warranty applies to purchases made from authorized retailers of SharkNinja Operating LLC. Warranty coverage applies to the original owner and to the original product only and is not transferable. SharkNinja warrants that the unit shall be free from defects in material and workmanship for a period of two (2)

years from the date of purchase when it is used under normal household conditions and maintained according to the requirements outlined in the Owner's Guide, subject to the following conditions and exclusions:

### **What is covered by this warranty?**

1. The original unit and/or non-wearable components deemed defective, in SharkNinja's sole discretion, will be repaired or replaced up to two (2) years from the original purchase date.
2. In the event a replacement unit is issued, the warranty coverage ends six (6) months following the receipt date of the replacement unit or the remainder of the existing warranty, whichever is later. SharkNinja reserves the right to replace the unit with one of equal or greater value.

### **What is not covered by this warranty?**

1. Normal wear and tear of wearable parts (such as foam filters, HEPA filters, pads, etc.), which require regular maintenance and/or replacement to ensure the proper functioning of your unit, are not covered by this warranty. Replacement parts are available for purchase at [sharkaccessories.com](http://sharkaccessories.com).
2. Any unit that has been tampered with or used for commercial purposes.
3. Damage caused by misuse (e.g., vacuuming up water or other liquids), abuse, negligent handling, failure to perform required maintenance (e.g., not cleaning the filters), or damage due to mishandling in transit.
4. Consequential and incidental damages.
5. Defects caused by repair persons not authorized by SharkNinja. These defects include damages caused in the process of shipping, altering, or repairing the SharkNinja product (or any of its parts) when the repair is performed by a repair person not authorized by SharkNinja.
6. Products purchased, used, or operated outside North America.

### **How to get service**

If your appliance fails to operate properly while in use under normal household conditions within the warranty period, visit [sharkclean.com/support](http://sharkclean.com/support) for product care and maintenance self-help. Our Customer Service Specialists are also available at 1-800-798-7398 to assist with product support and warranty service options, including the possibility of upgrading to our VIP warranty service options for select product categories.

SharkNinja will cover the cost for the customer to send in the unit to us for repair or replacement. A fee of \$24.95 (subject to change) will be charged when SharkNinja ships the repaired or replacement unit.

How to initiate a warranty claim

You must call 1-800-798-7398 to initiate a warranty claim. You will need the receipt as proof of purchase. A Customer Service Specialist will provide you with return and packing instruction information.

How state law applies

This warranty gives you specific legal rights, and you also may have other rights that vary from state to state. Some states do not permit the exclusion or limitation of incidental or consequential damages, so the above may not apply to you.

To better assist you, we ask that you register the product and have it with you when you call.

### **BATTERY REMOVAL AND DISPOSAL**

This product uses a rechargeable and reusable lithium-ion battery. When the battery no longer holds a charge, it should be removed from the hand vacuum and recycled. DO NOT incinerate or compost the battery.

When your lithium-ion battery needs to be replaced, dispose of it or recycle it in accordance with local ordinances or regulations. In some areas, it is illegal to place spent lithium-ion batteries in the trash or in a municipal solid waste stream. Return spent battery to an authorized recycling center or to retailer for recycling. Contact your local recycling center for information on where to drop off the spent battery.

For more information on battery removal for disposal, please visit [sharkclean.com/batterysupport](http://sharkclean.com/batterysupport)



The RBRC™ (Rechargeable Battery Recycling Corporation) seal on the lithium-ion battery indicates that the costs to recycle the battery at the end of its useful life have already been paid by SharkNinja. In some areas, it is illegal to place spent lithium-ion batteries in the trash or municipal solid waste stream and the RBRC program provides an environmentally conscious alternative.

RBRC, in cooperation with SharkNinja and other battery users, has established programs in the United States and Canada to facilitate the collection of spent lithium-ion batteries. Help protect our environment and conserve natural resources by returning the spent lithium-ion battery to an authorized SharkNinja service center or to your local retailer for recycling. You may also contact your local recycling center for information on where to drop off the spent battery, or call 1-800-798-7398.

## RECORD THIS INFORMATION

Model Number: \_\_\_\_\_

Date of Purchase: \_\_\_\_\_

(Keep receipt)

Store of Purchase: \_\_\_\_\_

© 2020 SharkNinja Operating LLC.

Needham, MA 02494/Ville St. Laurent, Québec H4S 1A7

1-800-798-7398

[sharkclean.com](http://sharkclean.com)

SHARK is a registered trademark of SharkNinja Operating LLC. WANDVAC is a trademark of SharkNinja Operating LLC. RBRC is a trademark of Rechargeable Battery Recycling Corporation.

For Shark | Ninja U.S. Patent information visit [sharkninja.com/uspateints](http://sharkninja.com/uspateints)

Printed in China.

Illustrations may differ from actual product.

WV200\_IB\_MP\_REV\_Mv9

---

## DOWNLOAD

**Shark WV200 WANDVAC Cordless Handheld Vacuum:**

Owner's Guide – [[Download PDF](#)]

---

