

# iHome

## AUTOVAC

### ECLIPSE



For support content and the latest digital copy of this manual, scan the QR code above or visit [iHomeclean.com](http://iHomeclean.com)

**Owner's Guide**  
Model iHRV10Y



# TABLE OF CONTENTS

1 .....	Safety
2 .....	In The Box
3 .....	Product Overview
4 .....	Dustbin Overview
5 .....	AUTOVAC Indicators
6 - 7.....	Setting up the Charging Dock
8 .....	Setting Up The AUTOVAC
9 .....	Using the iHome Clean App
10.....	Using Your AUTOVAC
11 .....	Using The Remote
12 .....	Main Brush Maintenance
13 .....	Maintaining the Dustbin and Filters
14.....	Side Brush and Sensor Maintenance
15.....	AUTOVAC Eclipse Troubleshoot

## Questions? Contact Customer Service

Web/Email: [iHomeclean.com](http://iHomeclean.com)

Phone: 877-370-4580

**Before using this product, please read the following safety instructions and follow all safety precautions. Any operation inconsistent with this instruction manual may cause damage to this product.**

**WARNING - To reduce the risk of fire, electric shock, or injury:**

- Do not use products in environments with open flames or fragile objects.
- Do not allow human hair, clothes, fingers and other parts to approach the opening and operate parts of the product.
- Do not allow the Eclipse to pick up objects such as stones and waste paper that may clog product.
- Do not allow the Eclipse to pick up flammable substances such as oil, printer toner and photocopier toner.
- Do not allow the Eclipse to pick up any burning articles, such as cigarettes, matches, ashes and other articles that may cause fire.
- Do not place objects near the suction port. Do not use the product when the suction port is blocked. Clean up the garbage dust, wool, hair, etc to ensure smooth air circulation at the suction port.
- Use the power cord carefully to avoid damage. Do not use the power cord to drag or pull the product and the charging base. Do not use the power cord as a handle.
- Only authorized technicians can disassemble this product. Users are not recommended to disassemble this product by themselves. Doing so will void warranty.
- Only use the included power adapter. Third part adapters may damage the Eclipse.
- Do not touch wires, sockets or power adapters when your hands are wet.
- Do not place this product near cigarette butts, lighters and other materials with smoldering fire.
- Please clean Dustbin and brushes regularly.
- Do not place any object, pets or people on top of the Eclipse.
- This product is an indoor household product. Do not use outdoors.
- Do not use this product in wet environment i.e, bathroom.
- Before using this product, please clear the floor of all objects other than furniture as some small objects may obstruct, get caught in, or damage the Eclipse.
- Please use and store Eclipse in room temperature environments only.

## FCC Information

**1:** This device complies with Part 15 of the FCC Rules. Operation is subject to the following two conditions: (1) This device may not cause harmful interference, and (2) This device must accept any interference received, including interference that may cause undesired operation.

**2:** Changes or modifications not expressly approved by the party responsible for compliance could void the user's authority to operate the equipment.

**NOTE:** This equipment has been tested and found to comply with the limits for a Class B digital device, pursuant to Part 15 of the FCC Rules. These limits are designed to provide reasonable protection against harmful interference in a residential installation. This equipment generates uses and can radiate radio frequency energy and, if not installed and used in accordance with the instructions, may cause harmful interference to radio communications. However, there is no guarantee that interference will not occur in a particular installation. If this equipment does cause harmful interference to radio or television reception, which can be determined by turning the equipment off and on, the user is encouraged to try to correct the interference by one or more of the following measures: Reorient or relocate the receiving antenna. Increase the separation between the equipment and receiver.

Connect the equipment into an outlet on a circuit different from that to which the receiver is connected. Consult the dealer or an experienced radio/TV technician for help.

- 1: Charging Dock
- 2: Autovac Eclipse
- 3: Charging Adapter

- 4: Remote
- 5: Extra HEPA Filter

- 6: Cleaning Tool
- 7: Extra Side Brush

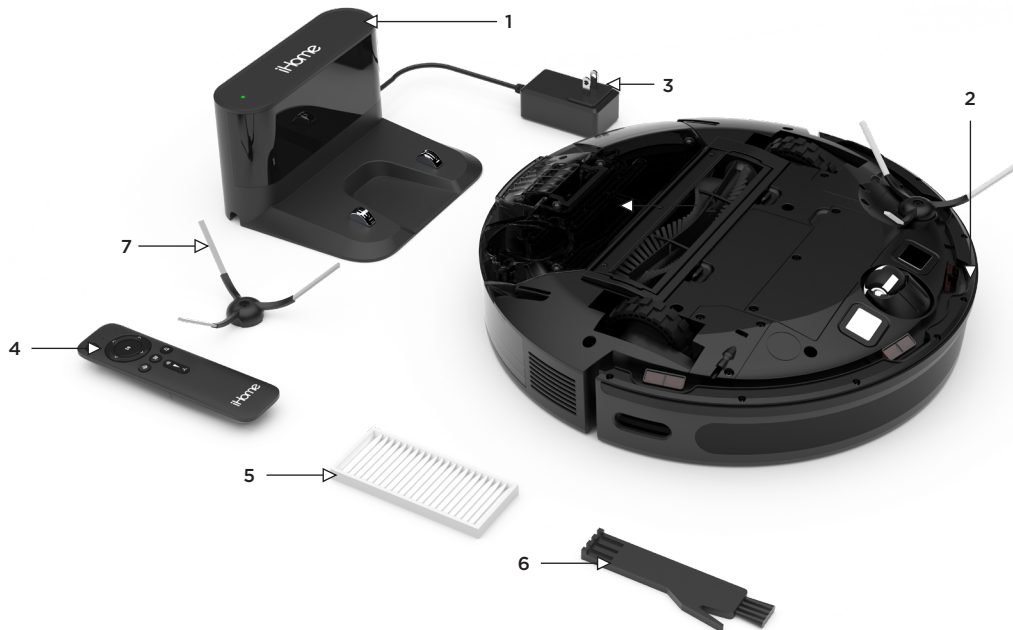

## Questions? Contact Customer Service

Web/Email: [iHomeclean.com](http://iHomeclean.com)

Phone: 877-370-4580

## FRONT

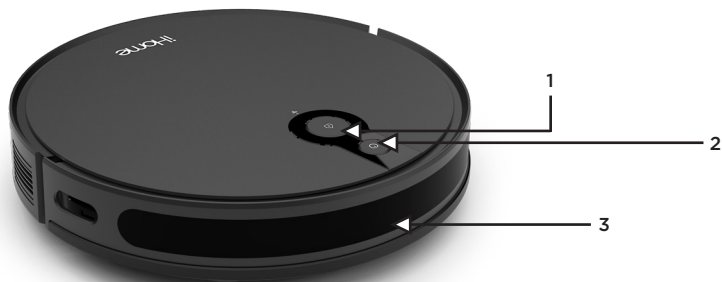

## CHARGING BASE

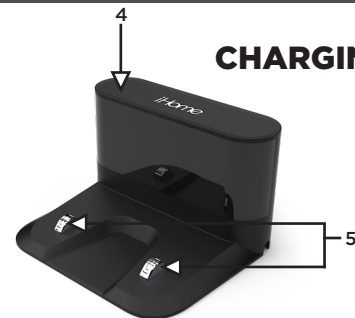

## BACK



## BOTTOM

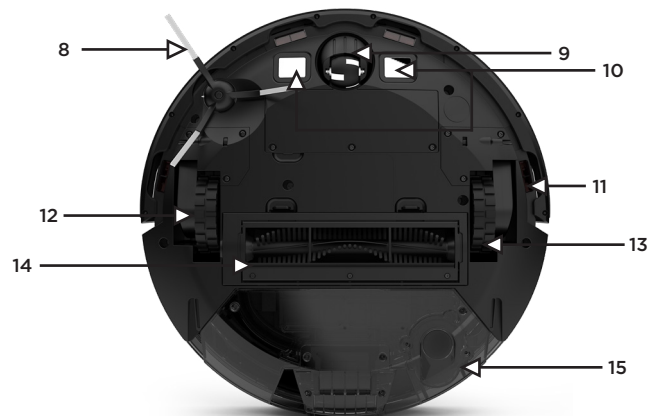

- 1: Home Button
- 2: Power Button
- 3: Infrared Sensors
- 4: Charging Indicator

- 5: Charging Contacts
- 6: Bin Release Button
- 7: Dustbin
- 8: Side Brush

- 9: Omnidirectional Wheel
- 10: Charging Contacts
- 11: Detection Sensors
- 12: Left Wheel

- 13: Right Wheel
- 14: Main Brush
- 15: Dustbin

- 1: Filter Door Latch
- 2: Bin Release Button

- 3: HEPA Filter
- 4: Screen Filter

- 5: Dustbin Latch

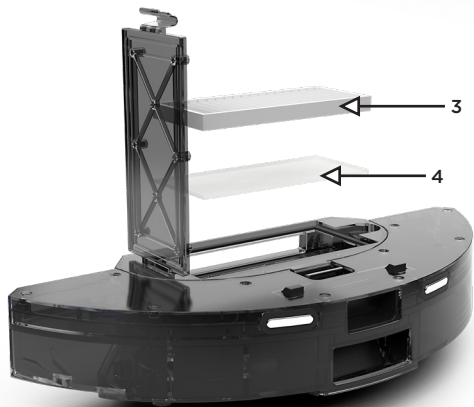
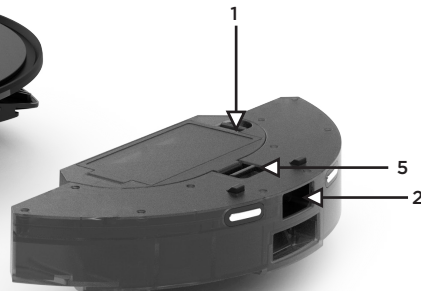



## ① POWER BUTTON

- Hold to turn on/off.
- Press to start/pause cleaning.

## ② HOME BUTTON

- Press to return to charging dock for recharging.

## ③ WIFI INDICATOR

## ④ CHARGING INDICATOR

## POWER/HOME LED STATES

- Flashing blue light: Powering on/configuring network/upgrading firmware.
- Solid blue light: Powered on/normal working state.
- Flashing yellow light: Low battery/recharging.
- Flashing green light: Charging.
- Solid green light: Fully charged.
- Flashing red light: Error state.
- Light off: Off/sleeping.

## WIFI INDICATOR STATES

- Flashing white light: Network configuration mode.
- Solid white light: Wifi connected.
- Light off: Wifi disconnected / Network configuration failure.

## CHARGING INDICATOR LED STATES

- LED will remain solid green when connected to wall power.

# SETTING UP YOUR AUTOVAC

---

The following pages outline the complete setup process. For your convenience we created a step-by-step video to help guide you through setup. Please scan the QR code to access the video and other support content.





## ABOUT YOUR CHARGING DOCK

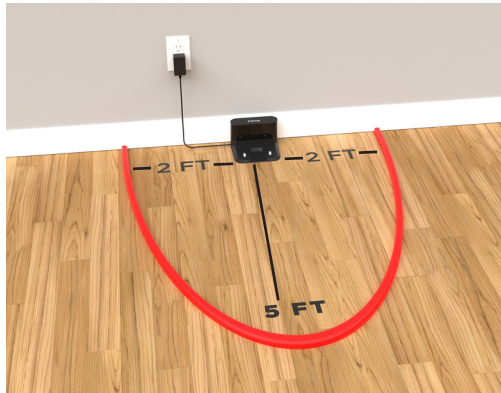

Place the charging dock against the wall and make sure the place is an open & uncluttered area. Leaving at least 5 feet in front of the charging dock; 2 feet on both sides of the charging dock.

**NOTE:** Clearance around the charging base is necessary to prevent obstructions when the Eclipse returns to charge. Avoid using a power source that may inadvertently be switched off (e.g. power strip, outlet controlled by a light switch, GFCI).

## SETTING UP THE CHARGING DOCK

- 1 Plug the power adapter into the port on the bottom of the charging dock and secure the cable into the channel.



- 2 Choose a location on a hard floor surface near a power outlet. Place the charging dock against the wall as shown. Plug the power adapter into a functioning wall outlet.





## STEP 1

Position the Eclipse on the floor near your charge dock as shown. To turn on Press and Hold the Power button until the indicator turns blue.



## STEP 2

Now press the  button . The Eclipse will navigate to the charging dock and beep when properly docked. The Home icon will flash green while charging and turn solid green when finished.



**NOTE:** Allow Eclipse to fully charge (up to 5 hours) before first use. The indicators on your robot will turn solid green when fully charged.

## UNDERSTANDING YOUR ECLIPSE

Your iHome Autovac is designed to automatically and methodically clean your home. Eclipse uses multiple sensors to clean your home efficiently, row by row. Cleaning history is available to view in the iHome Clean app. Once cleaning is finished or the battery is low, the Eclipse will automatically return to the charge dock.

## DOWNLOAD THE IHOME CLEAN APP

- Search “iHome Clean” in the App Store or use the QR code below:



**NOTE:** Connecting Eclipse to Wi-Fi is not required but highly recommended. Using the iHome Clean app, you can follow the steps to connect your Eclipse to Wi-Fi. The app will let you manage Eclipse from anywhere, set cleaning schedules, view cleaning history, access support and more!

The iHome Clean app provides an easy step by step guide to get your Eclipse connected to Wi-Fi. Here is a checklist of what you'll need before getting started:

- An iPhone (iOS 10 or later) OR Android (4.4 or later).
- Make sure that your phone is connected to your desired Wi-Fi Network. This will be the network that your Autovac Eclipse connects to.
- Your Wi-Fi network must be a 2.4Ghz network (5Ghz networks are not supported).
- Download and launch the iHome Clean app from the app store. Create a user account.
- Follow the steps in the app to add the Eclipse.

For your convenience we've created a video to walk through the App Setup process. Scan the QR code below to watch.



Before starting your first cleaning cycle please clear the floor of all objects other than furniture as some small objects may obstruct, get caught in, or damage the iHome Autovac Eclipse.

## FIRST CLEANING

Simply press the Power button on your Eclipse to begin an Auto-Clean cycle of your home. Eclipse will start cleaning and will continue until it has covered the entire cleaning area.

## CLEANING MODES

**Auto Clean** - The Eclipse will automatically clean your floor until it has covered the entire surface. Once cleaning is finished the Eclipse will automatically return back to charge.

**Manual Control** - Using the navigational D-Pad on the remote control (or in the iHome Clean App) you can manually control where the Eclipse goes to clean.

**Spot Clean** - The Eclipse will deep clean a specific spot. First, use the manual navigation control to guide your Eclipse to the desired location. Then, choose Spot Clean mode for a deep clean.

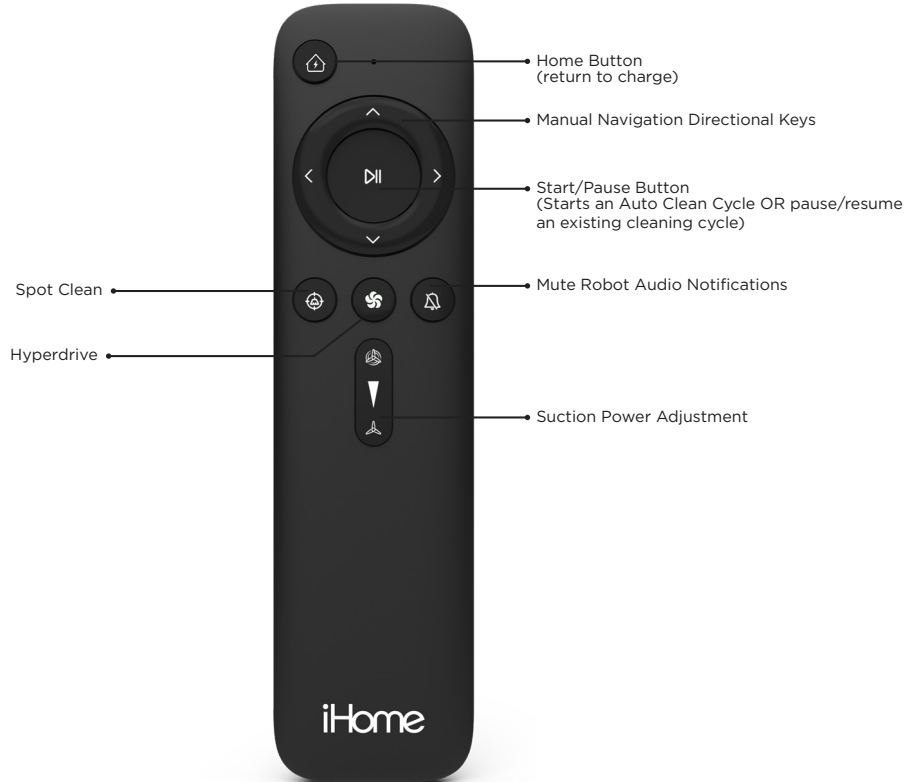
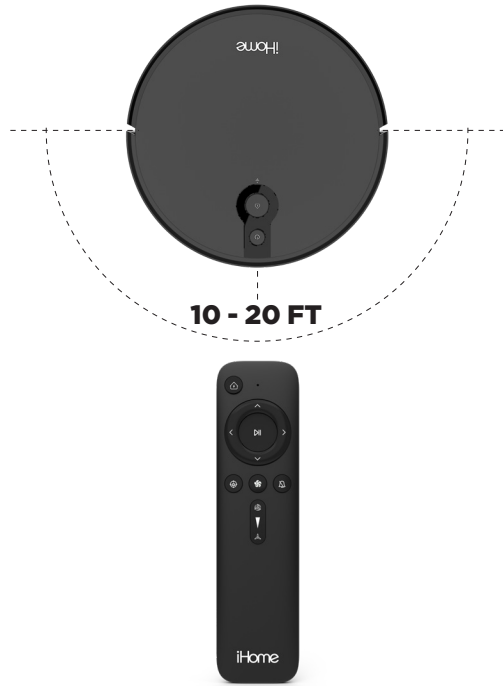

NOTE:  
1: It is recommended to point the remote to the front of the Eclipse for best results.  
2: The remote control range is 10 - 20 feet.

Your Eclipse is designed to be used regularly. As with most floor care devices, regular use may cause build-up around brushes, in debris compartments and near filters. We recommend performing regular maintenance, as outlined in the following pages, to keep your Autovac Eclipse running at optimal performance.

- 1: Pinch the left and right tabs on the main brush cover. Lift and remove the cover.
- 2: Remove the main brush and clean with the included cleaning tool as seen in the figure below.
- 3: Replace the main brush and snap the cover back into place.

**NOTE:** It is recommended to replace the main brush every 6-12 months depending on use.

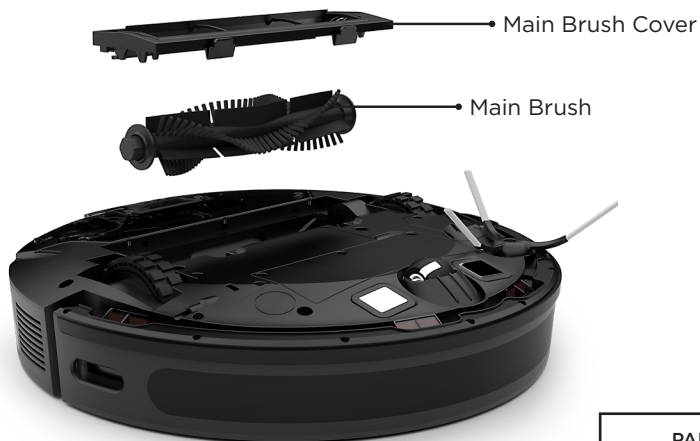

## MAINTENANCE SCHEDULE

PART	CARE FREQUENCY	REPLACEMENT FREQUENCY
Main Brush	Once a month	Replace every 6-12 months
Side Brushes	Once a month	Replace every 6-12 months
HEPA Filter	Every 2 Weeks	Replace every 3 months
Main Filter	Every 2 Weeks	Replace twice a year.

- ① Press the dustbin release button and remove the dustbin.



- ② Clean the inside of the dustbin thoroughly with a dry cloth.



- ③ Remove the primary filter and HEPA filter, wipe down the surface with a dry cloth or use the cleaning tool. Rinse the primary filter with water and let dry completely before using.

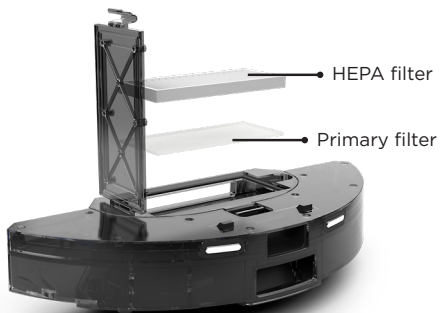

- 1: Use a Philips screwdriver to unscrew the side brush screw and remove the side brush.
- 2: Remove dirt and debris and reinstall using Philips screwdriver.
- 3: It is recommended to wipe dust from the charging pins on your robot and charge dock regularly.



**NOTE:** It is recommended to replace the side brush every 6-12 months depending on use.

---

## Questions? Contact Customer Service

Web/Email: [iHomeclean.com](http://iHomeclean.com)

Phone: 877-370-4580



## PROBLEM

## SOLUTION

Unable to power on	Please charge before use. This is commonly caused due to low battery.
Unable to start cleaning	Please charge before use. This is commonly caused due to low battery.
Unable to return to charging dock	<ul style="list-style-type: none"> <li>• There are too many obstacles near the charging dock. Please make sure there is a clear area 2 FT of space on either side and 5 FT in front of the charging dock.</li> <li>• Eclipse is out of range of the charging dock. Move the Eclipse closer to the charging dock to re-establish connection.</li> </ul>
Abnormal behavior	Please make sure the areas to be cleaned are well illuminated. Clean the lens with a clean soft cloth, and make sure the sensor is not blocked. Avoid using any detergent or cleaning spray while cleaning
Abnormal noise during cleaning	Main brush, side brush or left/right wheel may be obstructed, Check underneath the Eclipse to make sure it is clear from any obstruction. If there is an obstruction clear it and restart the Eclipse.
Decrease in cleaning ability or dust falling out from dustbin	<ul style="list-style-type: none"> <li>• The dustbin is full, please empty the dustbin.</li> <li>• Check and clean the HEPA filter.</li> <li>• Check that the brush is clear from obstruction.</li> </ul>
Unable to connect to Wi-Fi	Wi-Fi signal is not good , please check that there is a strong Wi-Fi connection while paring. Make sure the network is 2.4G and not 5G or dual band.
Eclipse is not returning to the charging dock after spot cleaning or after moving it far from the charging dock	After spot cleaning or moving the Eclipse far from the charging dock the Eclipse will re-generate the map. If the Eclipse is far from the charging dock it may not be able to locate it. Please manually dock the Eclipse to the charging dock to recharge.
Unable to charge after docking	Make sure there is no obstruction or heavy dust on both the Eclipse and charging dock charging contacts.
Scheduled cleaning not working	Please confirm that the Eclipse is connected to your Wi-Fi network.If the Eclipse is not connected to the network you cannot synchronize the scheduled cleaning task.